

# Expanding the Use of Smart Operator Panels

Author: Advantech

E-mail: [eainfo@advantech.com](mailto:eainfo@advantech.com)

The evolution of operator interfaces has moved quite far beyond the pushbutton you see below. Once, the intelligence resided in the operator's brain and considerable experience and training were required to operate any complex piece of machinery or process. The evolution of the operator panel is actually two parallel evolutionary tracks. First is the movement of that intelligence from the operator's brain into the operator panel itself. So, we now refer to them as "smart operator panels." The other track is how the evolution of the operator panel tracks Moore's Law, making them incredibly more powerful and less expensive over and over.



Smart operator panels permit the operator to have access to large amounts of information in one location, on one or just a few screens. This may include process data, quality data, performance of the cell, unit or batch, as well as the controls for the system themselves. Even with a quite small display such as the Advantech WebOP-2035V (a 3.5 inch display).

Note the number of data types that can be displayed on this operator

panel, yet it is small enough to mount directly to a control pedestal or on a machine itself.

This versatility has helped to drive the adoption of smart operator panels in many industries and by many machine builders as well.



## So what is a Smart Operator Panel?

A smart operator panel is really a computer—an embedded computer complete with input/output, memory, a processor, and a display (usually a touchscreen) in an enclosure that is suitable to the environment the panel will be used in, from rack mount to enclosures that are waterproof or explosion proof. Regardless of the size of the display (for example, Advantech produces display sizes from 3.5 to 12.1 inch in the WebOP series of smart operator panels) the panel is connected to a field controller, such as a PLC or PAC, which does the control of the machine or process.

The operator panel serves many functions formerly handled by multiple devices. It is a control panel, with push-button analogs and displays. It can be used as a data-logger, and sometimes a sequence-of-events recorder, and can provide "help" functions that can assist operators with decision support.

Operator panels are supplied in a variety of enclosures, are often not fan-cooled, and have a variety of displays, mostly flat panel as shown here. The enclosure design varies depending on what the actual in-use environment is for the panel. Panels that are installed in food processing plants or pharmaceutical plants may require waterproof electrical classification enclosures to withstand wash-down operations. Panels that are installed in assembly line applications where grime and dirt are problems are usually built without fans for cooling and installed in sealed enclosures.



### Operator Panels with Multiple Controllers

One of the great benefits of smart operator panels is the fact that they can be used to provide HMI interfaces with many controllers. As the figure below shows, the operator panel can be connected to PLCs and other operator panels in a variety of useful ways, including remotely over Ethernet, directly over RS-232, and other linkages. This makes communication with the smart operator panel simple and effective and makes it possible to optimize the uses of smart operator panels without having to buy one for every controller or function in the plant.

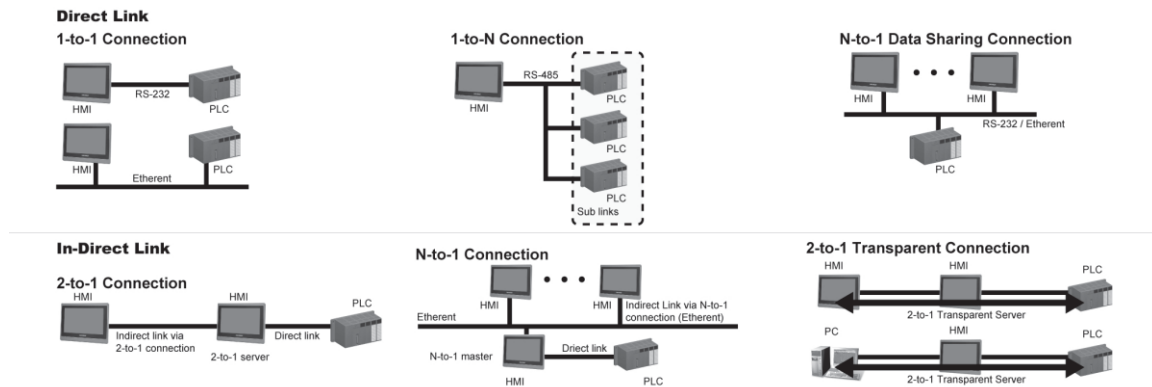

### Applications for Smart Operator Panels

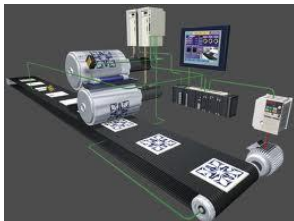

There are a wide variety of applications for smart operator panels—many more than just serving as the HMI for a PLC. They can operate to be an HMI for a motion controller or an entire motion control system, even using PLCs or PACs made by different vendors.

They can be used to operate PID control loops and program in function blocks. Because of this, they can be thermal controllers and inverters. With an appropriate controller, they can replace the standard standalone loop controller, and provide benefits like data historian and data logging, multiple loop control capability, and even contextual help functions for operators.

They can be used as the communications mechanism and the HMI for smart sensors, and they can act as a microprocessor-base proprietary controller.



## Smart Operator Panel Manages Packaging Application

The use of these smart operator panels reduces the complexity of wiring, programming, and operation because the panel's versatility can be depended on to replace a whole slew of formerly independent devices, like pushbuttons, controllers, data-loggers, and so forth.

### Intelligence Made Easy

A Smart Operator Panel needs programming software, and the utility of the hardware is well defined by the software. The programming software needs to be very simple to learn to use. It doesn't matter how powerful a software package is, if it takes far too long to learn it.

A software package like Advantech's WebOP Designer 2.0 is an example of such a runtime HMI development software package. A listing of its features can be used to benchmark the features of other software packages:

- Allows users to manage multiple HMI applications in one project with a single database
- Allows users to switch multi-language UI dynamically, with Unicode and multilingual screen text supported
- Provides password protection of designs, macros and upload/download operations
- Supports vertical or horizontal screen displays
- Enables one design to fit all HMI models from 5.7 inch to 12.1 inch displays
- Provides index registers for modifying device addresses at runtime
- Collects data from many devices with various methods
- Supports various data acquisition and trend presentation protocols
- Operation log helps the review and investigation of important events
- Allows downloading the runtime data using serial port, Ethernet port, USB client port at HMI and Micro-SD.
- Allows use of a USB Memory Stick for trouble-free updating of the application
- Supports all the major industrial communication protocols and PLC/PAC devices.

Any good development software package should have at least these features. Advantech's WebOP Designer package supports global tag databases and global macros. In addition, it comes with a pre-designed library of screen objects, from pushbuttons to graphs and charts. And since automation systems are increasingly less "islanded" a good development software package needs



a robust utility, like Advantech's DTH data transfer helper, to move data easily and quickly, even to remote sites outside the factory floor.

The programming software package and the Graphical Operator Panel interface are taking over from the wired pushbutton panels of the past. The increase in capability coupled with the decrease in cost predicted by Moore's Law means that Smart Operator Panels will become smarter, more durable, more powerful and simpler to use. New operating systems and new web-based design and interface tools are changing the way we design the operation of systems.